

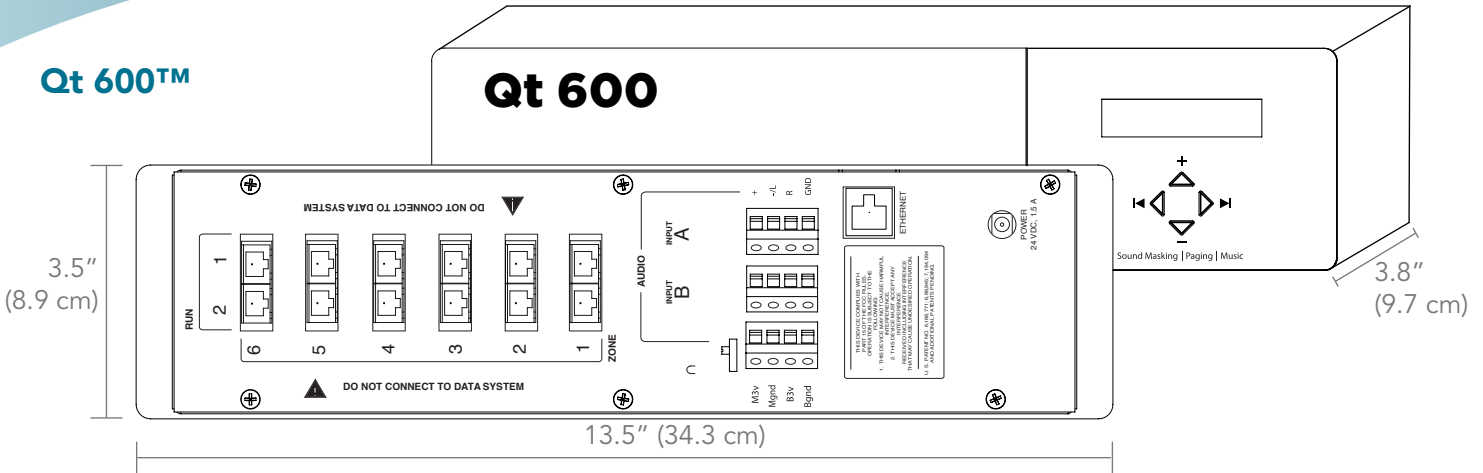

Qt 600™



APPLICATION

The Qt 600 control module is a sound masking generator, controller, third octave band equalizer and amplifier, with two aux audio inputs to allow for distribution of audio from paging controllers and/or (background) music players. The Qt 600 control module is a compact six-zone networkable controller suitable for installations of up to 72,000 square feet (6,689 m²). Each zone can be independently adjusted for masking and aux audio levels and spectra. Levels can be adjusted from the unit's front panel or from a remote desktop leveraging the unit's network connectivity and browser-based GUI.

HOW TO SPECIFY

Module	Mounting Options
Qt 600	WM (Wall Mount)
	RM (Rack Mount)

HRC*	Color	Cable Lengths May be specified
HRC	W (White)	50ft (15.2 m)
	B (Black)	100ft (30.5 m)
		C [Length] (made to order)

*HRC = Home Run Cable: the cable from the control module to the first emitter of a run; longer than on the 16' (4.9 m) emitter to emitter cable.

Examples:

- Qt 600-WM A Qt 600 control module with wall mount bracket
- Qt 600-RM A Qt 600 control module with rack mount bracket
- HRC-W-100 A 100 ft (30.5 m) white CAT-3 cable with dual RJ-45 terminations
- HRC-B-C62 A 62 ft (18.9 m) black CAT-3 cable with dual RJ-45 terminations, made to order



WALL MOUNT INSTALLATION

Wall mount bracket comes standard with controller. When wall mounted, the chassis flips down for easy access to all rear input connections.

RACK MOUNT INSTALLATION

The rack mount kit permits mounting of the controller onto an industry standard 19" (48.3 cm) EIA or NEMA equipment rack.

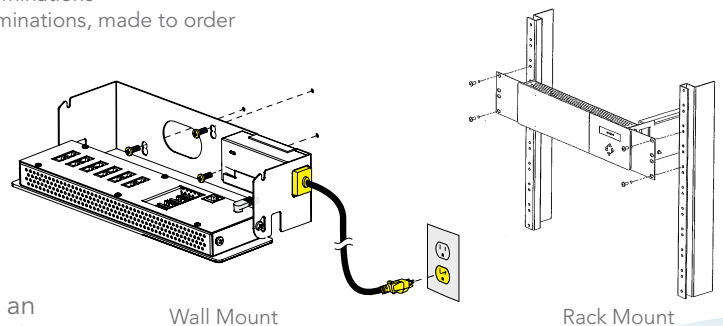

TECHNICAL SPECIFICATIONS

Dimensions: W x H x D	13.5" x 3.5" x 3.8" (34.3 cm x 8.9 cm x 9.7 cm)
Weight	3.0 lbs (1.4 kg)
Operating Temperature Range	40°F - 90°F (4°C - 32°C)
Power Requirements	100 - 240 VAC, 24 watts
Zones	6
Emitter Run Connector Type	RJ-45 (Bent 3-tyne)
Aux. Audio Inputs	2 fixed terminal blocks
Aux. Audio Input Level	-10 dBV Nominal, 2 Vrms max
Aux. Input Equalization	Adjustable +/- 12 dB in ISO standard octave bands
Emitter Capacity	60 per run, 120 per zone, 720 total
Max. Coverage Area (10' Ceiling)	72,000 ft ² (6,689 m ²)
Masking Spectrum	Preset at factory to CSM standard spectrum (recommended).
Masking Spectrum Equalization	Adjustable +/- 12 dB in ISO standard 1/3 octave bands
Masking Channels	4 per zone
Time of Day Masking Level Control	RTC with battery backup. Per-zone day/night levels and start times, ramping interval, and weekday/Sat/Sun behavior
Network Access for Control and Monitoring	Yes
Security	"Hidden" front-panel lock switch; username and password required for network access; fixed terminal block contact closure

STANDARDS AND CERTIFICATIONS

ASTM E1130-08	✓
GreenSpec Listed	✓
FCC Part 15 Compliant	✓
RoHS Compliant	✓
CE	✓
Safety	- Conforms to: - US STD 60065 - CAN/CSA STD C22 2 60065 - ETL Listed

CABLE SPECIFICATIONS

Cables are plenum-rated, solid conductor 24AWG CAT-3, pre-terminated with bent 3-tyne (prong) contacts straddling each conductor in RJ-45 connectors. Cables are straight through and terminated in T568B wiring scheme. Cables are tested for continuity.

ARCHITECTURAL SPECIFICATIONS

The controller shall consist of all electronics required for operating a sound masking system from a single accessible location. Systems with distributed electronic packages above ceilings are not acceptable. The controller shall permit password protected access for control and monitoring via LAN/Browser interface. The controller shall provide six zones and shall be sufficient to generate sound masking, audio control and audio power for up to 72,000 square feet (6,689m²) of coverage. The unit shall be capable of time-of-day masking level control; per-zone settings shall be available for day/night levels and start times, ramping interval, and weekday/Sat/Sun behavior. Each audio output shall provide 4 incoherent channels of masking noise to minimize phase interference and hotspots. The complete system shall consume less than 24 watts of power. The unit shall meet all requirements of Underwriters Laboratories, the US and Canadian National Electrical Codes, FCC Part 15, and all pertinent UK and EU codes.

